

Lensagon B2M3814C

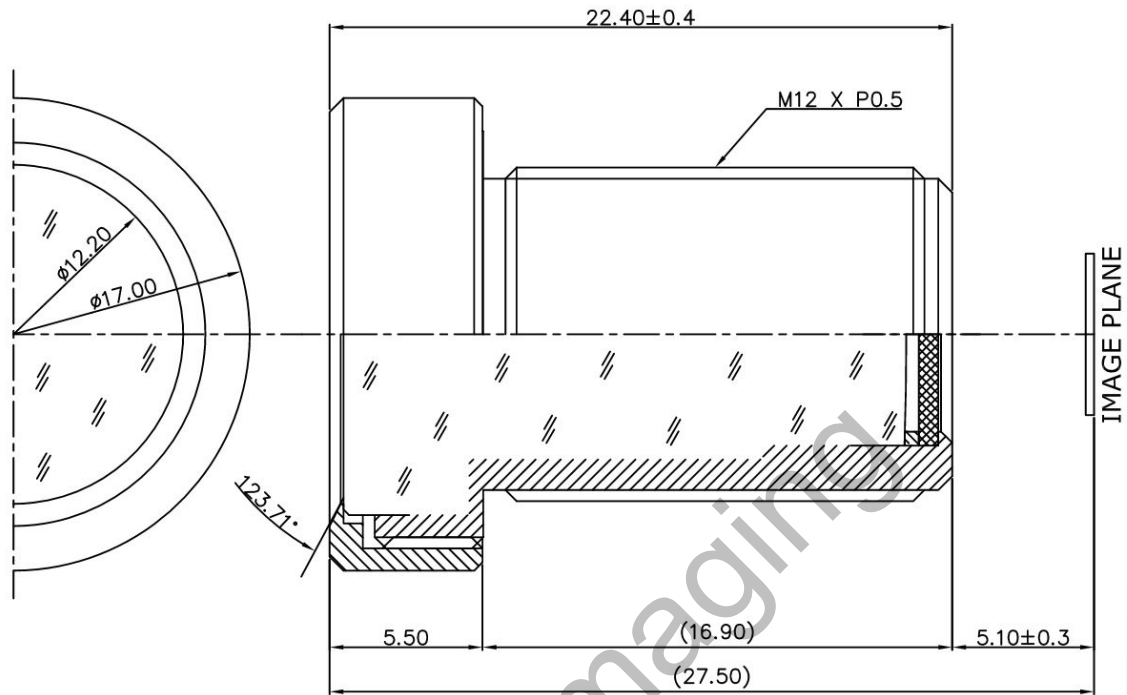

The S-Mount lens Lensagon B2M3814C is suitable for common sensors up to 2 megapixel with an image format of 1/2.5 inch. It is characterized by a particularly high light intensity.

Technical Data

Mount	S-Mount
Sensor	1/2.5 inch
Focal Length	3.85 mm
Aperture	1.4
Back Focal	6.76 mm
Angle of View	D:121.9° H:91.1° V:56°
Megapixel	2 MP
IR Cut Filter	Yes
Image Circle	7.2 mm
Iris	fixed
Focus	fixed
Typ	Standard

SEDECO
IMAGING

Germany, Austria, Switzerland
Sedeco Imaging GmbH
Unterer Dammweg 12
76149 Karlsruhe
Germany
T. +49 721 5604 7980
info@sedeco-imaging.com

BeNeLux
Sedeco Imaging B.V.
Trasmolenlaan 12
3447 GZ Woerden
the Netherlands
T. +31 348 749110
info@sedeco-imaging.nl

www.sedeco-imaging.com



Light Sensitive



Megapixel