

# B2M10030N2C

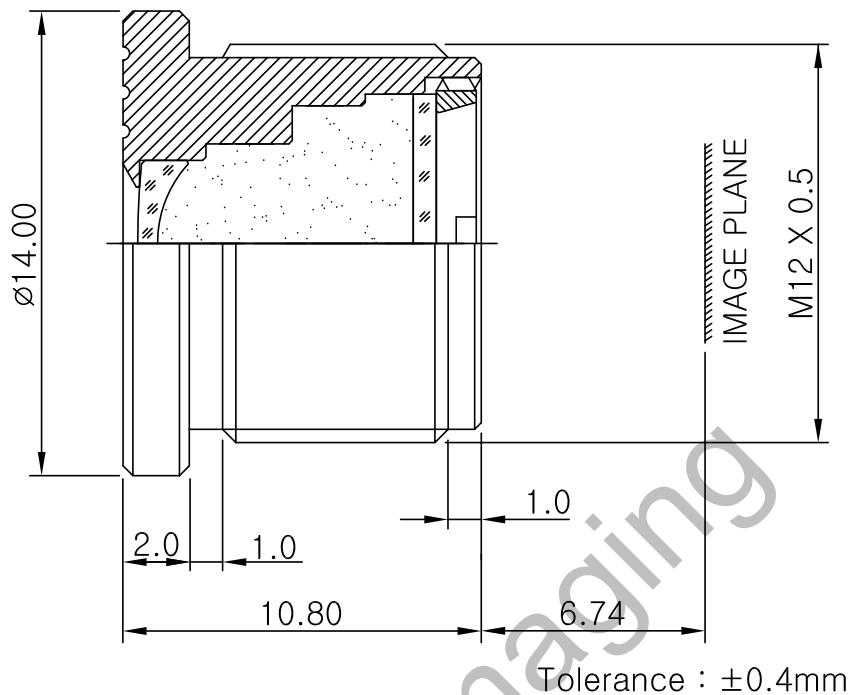

The S-Mount lens Lensagon B2M10030N2C is suitable for common sensors up to 2 megapixel with an image format of 1/2 inch. Infrared radiation is filtered reliably through the built-in IR cut filter.

## Technical Data

Mount	S-Mount
Sensor	1/2 inch
Focal Length	10.3 mm
Aperture	3
MOD	0.2 m
Back Focal	8.77 mm
Angle of View	D:54° H:° V:°
Megapixel	2 MP
IR Correction	IR Cut
IR Cut	Yes
Distortion	2.1 %
Iris	fixed
Focus	fixed
Typ	Standard

**SEDECO**  
IMAGING

Germany, Austria, Switzerland  
Sedeco Imaging GmbH  
Unterer Dammweg 12  
76149 Karlsruhe  
Germany  
T. +49 721 5604 7980  
info@sedeco-imaging.com

BeNeLux  
Sedeco Imaging B.V.  
Trasmolenlaan 12  
3447 GZ Woerden  
the Netherlands  
T. +31 348 749110  
info@sedeco-imaging.nl

[www.sedeco-imaging.com](http://www.sedeco-imaging.com)



**2** Megapixel

**IR** IR Cut Filter