

B2M10030N2

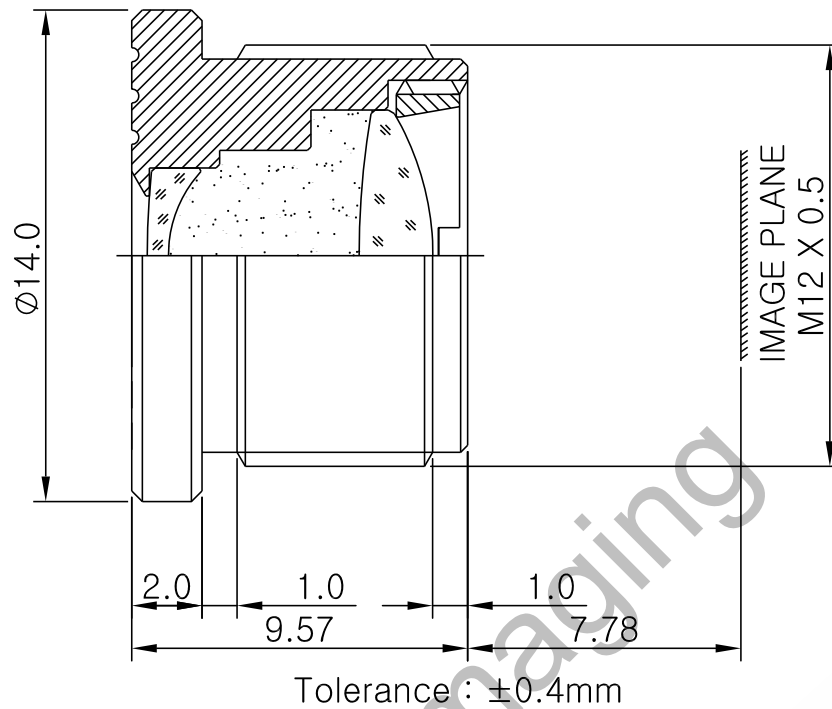

The S-Mount lens Lensagon B2M10030N2 is suitable for common sensors up to 2 megapixel with an image format of 1/2 inch.

Technical Data

Mount	S-Mount
Sensor	1/2 inch
Focal Length	10.3 mm
Aperture	3
MOD	0.2 m
Back Focal	8.77 mm
Angle of View	D:41.5° H:33° V:25°
Megapixel	2 MP
IR Cut	No
Distortion	2.1 %
Iris	fixed
Focus	fixed
Typ	Standard

SEDECO
IMAGING

Germany, Austria, Switzerland
Sedeco Imaging GmbH
Unterer Dammweg 12
76149 Karlsruhe
Germany
T. +49 721 5604 7980
info@sedeco-imaging.com

BeNeLux
Sedeco Imaging B.V.
Trasmolenlaan 12
3447 GZ Woerden
the Netherlands
T. +31 348 749110
info@sedeco-imaging.nl

www.sedeco-imaging.com



2 Megapixel