

# BM5518S12NDC

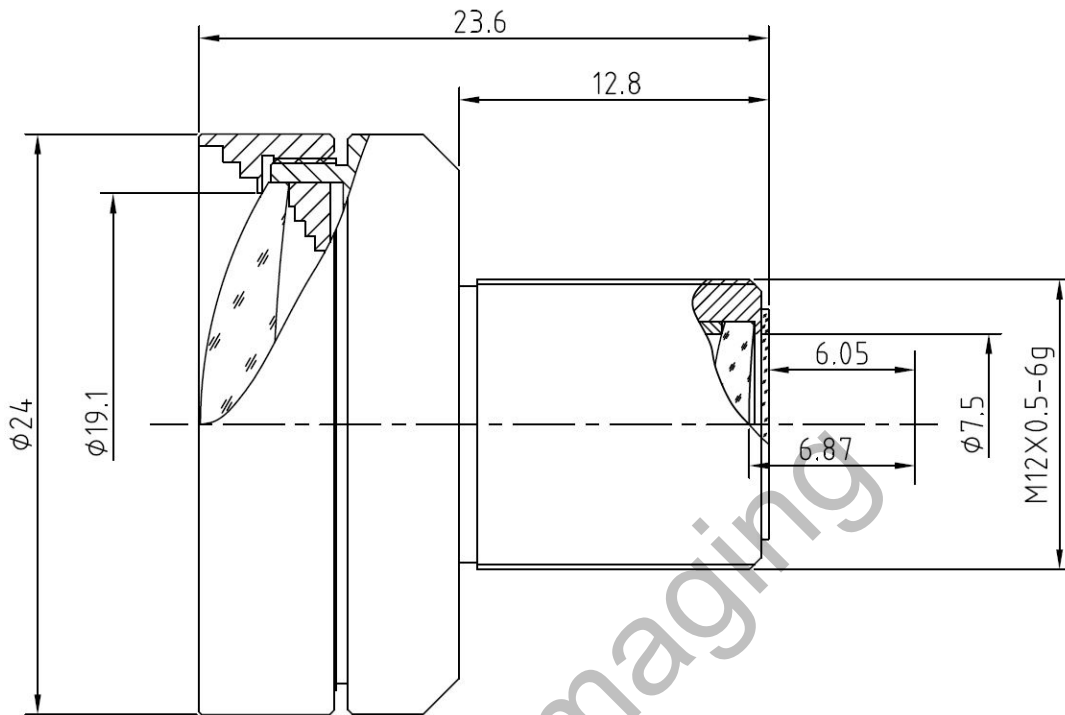

The S-Mount lens Lensagon BM5518S12NDC is suitable for common sensors up to 2 megapixel with an image format of 1/1.8 inch. It is characterized by a particularly high light intensity.

## Technical Data

Mount	S-Mount
Sensor	1/1.8 - 1/2 inch Sensor
Focal Length	5.5 mm
Aperture	1.8
MOD	0.2 mm
Back Focal	6.87 mm
Angle of View	D:76° H:64.5° V:51°
Megapixel	2 MP
IR Cut Filter	Yes
Distortion	2.2 %
Weight	15 g
Iris	fixed
Focus	fixed
Typ	Standard

**SEDECO**  
IMAGING

Germany, Austria, Switzerland  
Sedeco Imaging GmbH  
Unterer Dammweg 12  
76149 Karlsruhe  
Germany  
T. +49 721 5604 7980  
info@sedeco-imaging.com

BeNeLux  
Sedeco Imaging B.V.  
Trasmolenlaan 12  
3447 GZ Woerden  
the Netherlands  
T. +31 348 749110  
info@sedeco-imaging.nl

[www.sedeco-imaging.com](http://www.sedeco-imaging.com)



Light Sensitive



Megapixel