

B5M29740ND

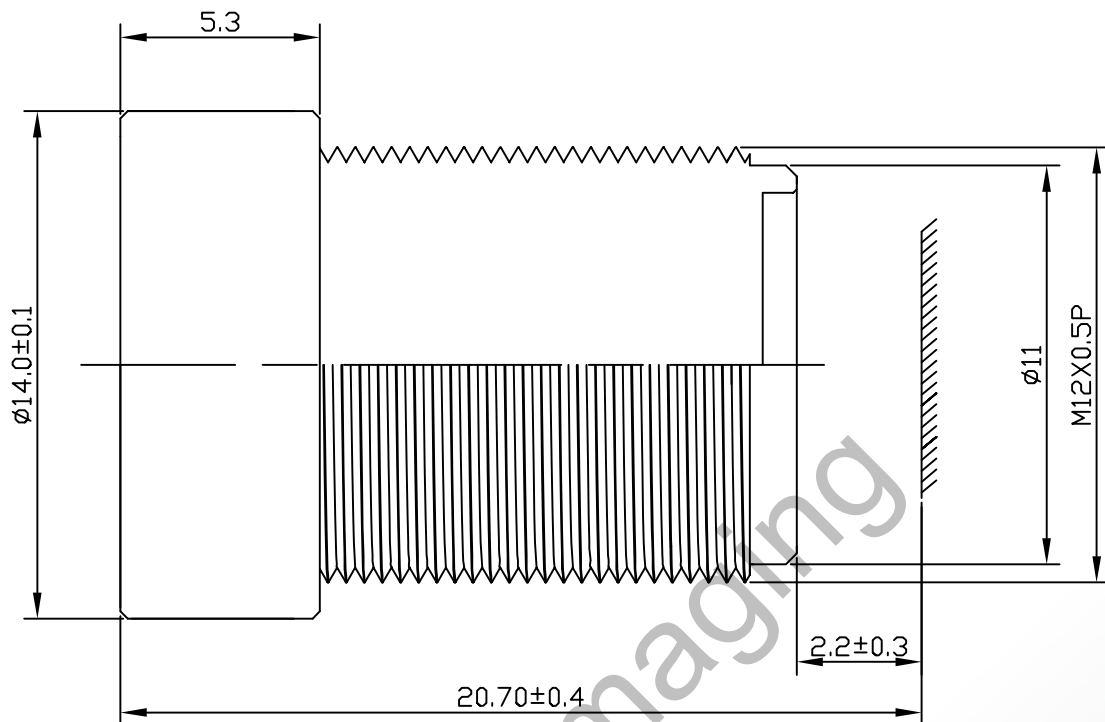

The S-Mount lens Lensagon B5M29740ND is suitable for common sensors up to 5 megapixel with an image format of 1/2.5 inch. 2 plastic lenses inside.

Technical Data

Mount	S-Mount
Sensor	1/2.5 inch
Focal Length	2.97 mm
Aperture	4
MOD	0.2 m
Back Focal	2.97 mm
Angle of View	D:100° H:87.2° V:71.1°
Megapixel	5 MP
IR Cut	No
Distortion	1 %
Weight	3.5 g
Iris	fixed
Focus	fixed
Typ	Standard

Hinweis:

5 Megapixel

SEDECO
IMAGING

Germany, Austria, Switzerland
 Sedeco Imaging GmbH
 Unterer Dammweg 12
 76149 Karlsruhe
 Germany
 T. +49 721 5604 7980
 info@sedeco-imaging.com

BeNeLux
 Sedeco Imaging B.V.
 Trasmolenlaan 12
 3447 GZ Woerden
 the Netherlands
 T. +31 348 749110
 info@sedeco-imaging.nl

www.sedeco-imaging.com

