

# Lensagon BM6020ND

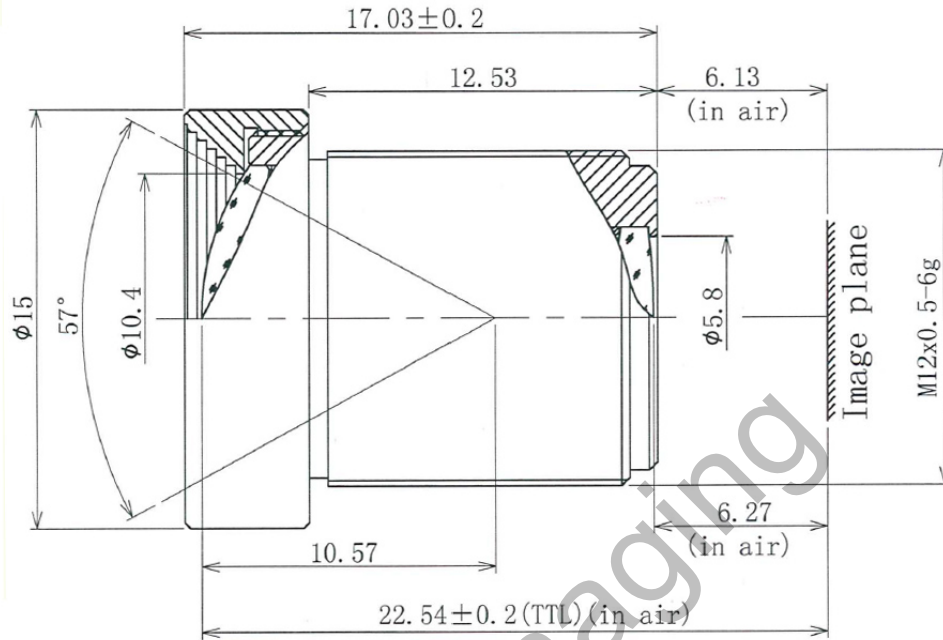

The S-Mount lens Lensagon BM6020ND is suitable for common sensors up to 1 megapixel with an image format of 1/3 inch. It is characterized by a particularly high light intensity. IR Correction up to 840nm

## Technical Data

Mount	S-Mount
Sensor	1/3 inch
Focal Length	6 mm
Aperture	2
MOD	0.2 m
Back Focal	6.27 mm
Angle of View	D:57° H:46.8° V:35.7°
Megapixel	1-2 MP
IR Correction	Yes
Distortion	-2.6 %
Iris	fixed
Focus	fixed
Typ	Standard

**SEDECO**  
IMAGING

Germany, Austria, Switzerland  
Sedeco Imaging GmbH  
Unterer Dammweg 12  
76149 Karlsruhe  
Germany  
T. +49 721 5604 7980  
info@sedeco-imaging.com

BeNeLux  
Sedeco Imaging B.V.  
Trasmolenlaan 12  
3447 GZ Woerden  
the Netherlands  
T. +31 348 749110  
info@sedeco-imaging.nl

[www.sedeco-imaging.com](http://www.sedeco-imaging.com)



Light Sensitive



1 Megapixel