

BM10028S12C

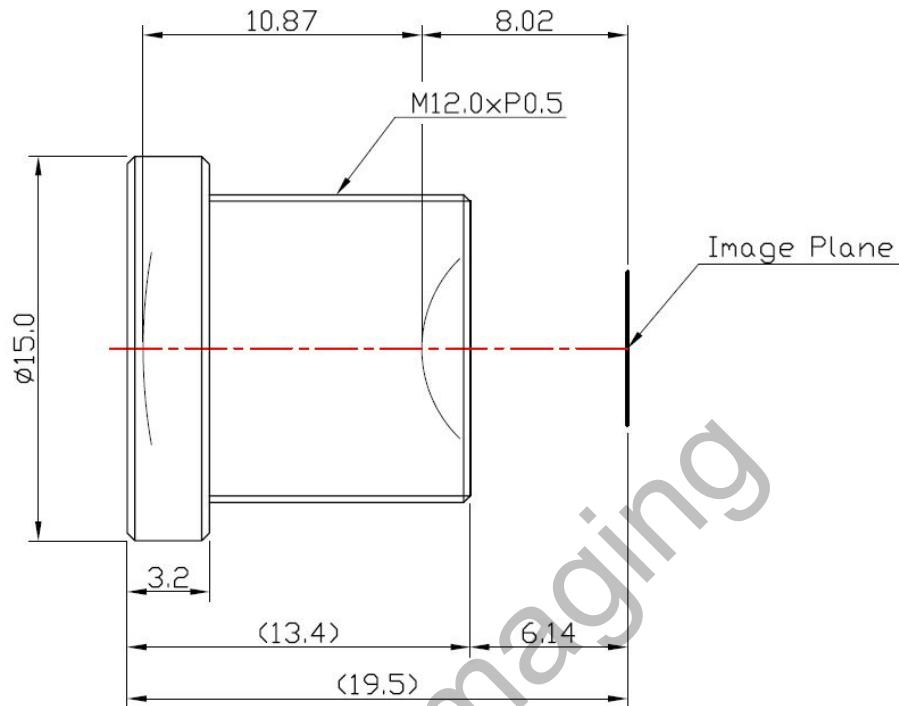

The S-Mount lens Lensagon BM10028S12C is suitable for common sensors up to 1 megapixel with an image format of 1/2 inch.

Technical Data

Mount	S-Mount
Sensor	1/2 inch
Focal Length	10.06 mm
Aperture	2.8
Back Focal	8 mm
Angle of View	D:44° H:36° V:27°
Megapixel	1-2 MP
IR Cut Filter	Yes
Weight	5 g
Iris	fixed
Focus	fixed

SEDECO
IMAGING

Germany, Austria, Switzerland
Sedeco Imaging GmbH
Unterer Dammweg 12
76149 Karlsruhe
Germany
T. +49 721 5604 7980
info@sedeco-imaging.com

BeNeLux
Sedeco Imaging B.V.
Trasmolenlaan 12
3447 GZ Woerden
the Netherlands
T. +31 348 749110
info@sedeco-imaging.nl

www.sedeco-imaging.com



1

Megapixel