

# BM10028S12

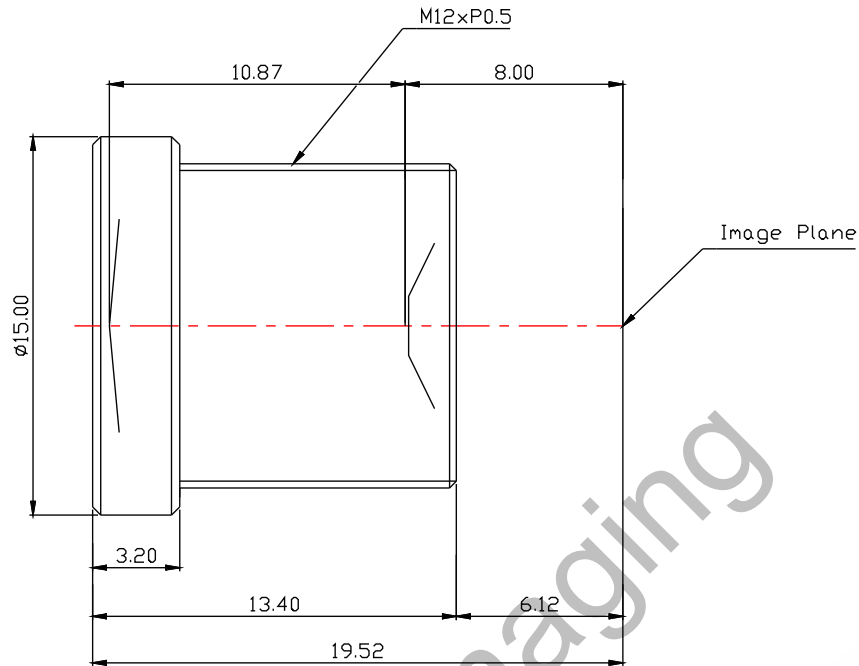

The S-Mount lens Lensagon BM10028S12 is suitable for common sensors up to 1 megapixel with an image format of 1/2 inch.

## Technical Data

Mount	S-Mount
Sensor	1/2 inch
Focal Length	10.06 mm
Aperture	2.8
Back Focal	8 mm
Angle of View	D:44° H:36° V:27°
Megapixel	1-2 MP
IR Cut Filter	No
Weight	5 g
Iris	fixed
Focus	fixed
Typ	Standard

**SEDECO**  
IMAGING

Germany, Austria, Switzerland  
Sedeco Imaging GmbH  
Unterer Dammweg 12  
76149 Karlsruhe  
Germany  
T. +49 721 5604 7980  
info@sedeco-imaging.com

BeNeLux  
Sedeco Imaging B.V.  
Trasmolenlaan 12  
3447 GZ Woerden  
the Netherlands  
T. +31 348 749110  
info@sedeco-imaging.nl

[www.sedeco-imaging.com](http://www.sedeco-imaging.com)



**1** Megapixel