

Lensagon B5M2916

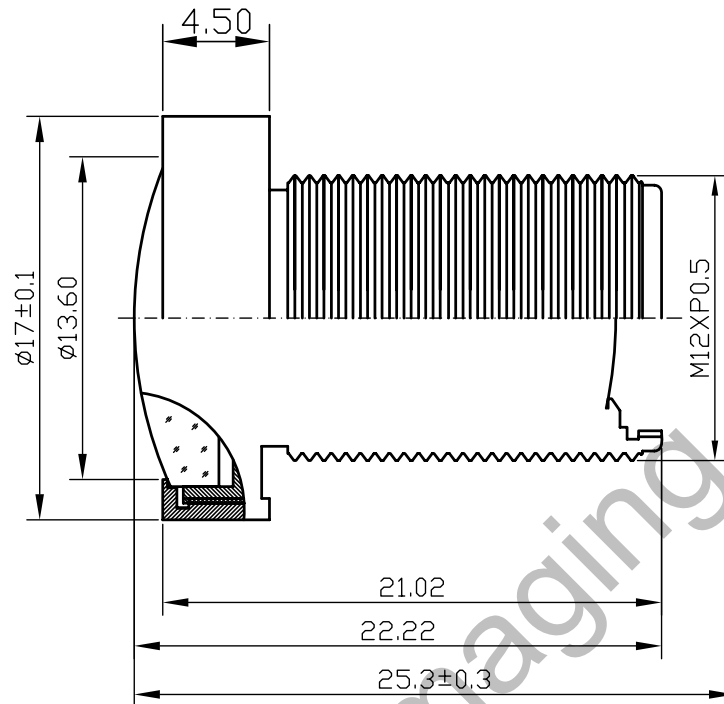

The S-Mount lens Lensagon B5M2916 is suitable for common sensors up to 5 megapixel with an image format of 1/2.5 inch. It is characterized by a particularly high light intensity.

Technical Data

Mount	S-Mount
Sensor	1/2.5 inch
Focal Length	2.9 mm
Aperture	1.6
MOD	0.1 m
Back Focal	5.1 mm
Angle of View	D:152° H:117.5° V:86.5°
Megapixel	5 MP
IR Cut	No
Distortion	-63 %
Iris	fixed
Focus	fixed
Typ	Standard

SEDECO
IMAGING

Germany, Austria, Switzerland

Sedeco Imaging GmbH
Unterer Dammweg 12
76149 Karlsruhe
Germany
T. +49 721 5604 7980
info@sedeco-imaging.com

BeNeLux

Sedeco Imaging B.V.
Trasmolenlaan 12
3447 GZ Woerden
the Netherlands
T. +31 348 749110
info@sedeco-imaging.nl

www.sedeco-imaging.com



Light Sensitive



5 Megapixel