

# Lensagon B16020S12

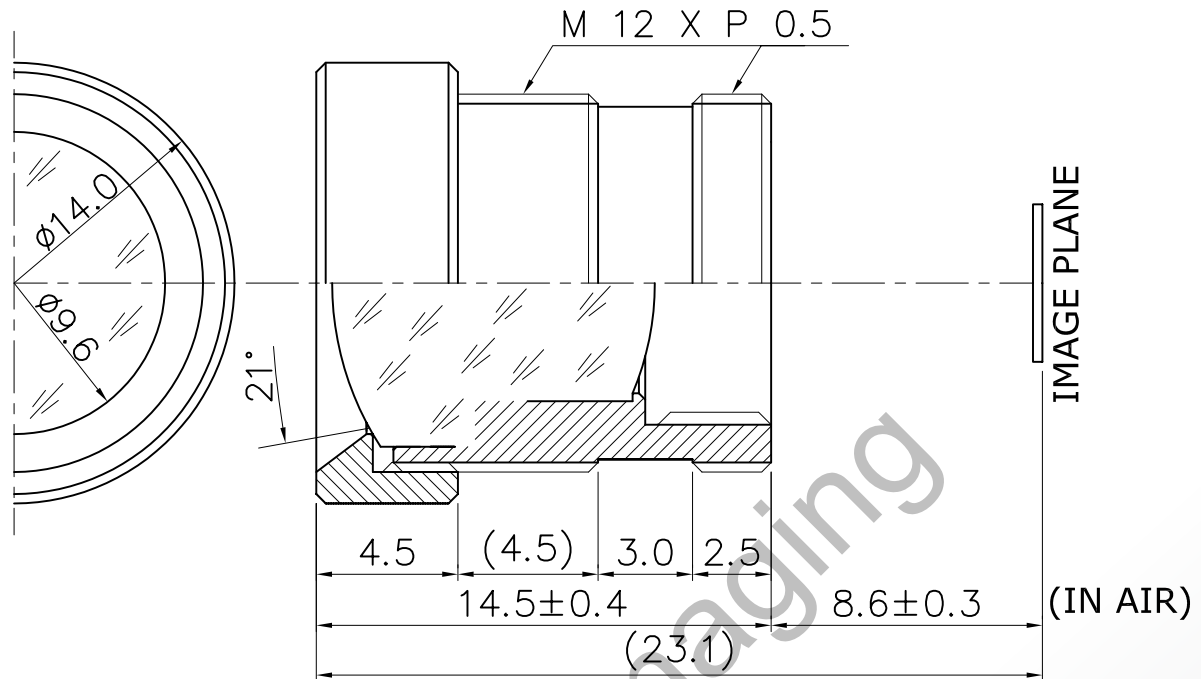

The S-Mount lens Lensagon B16020S12 is suitable for common sensors up to 1 megapixel with an image format of 1/2 inch. It is characterized by a particularly high light intensity.

## Technical Data

Mount	S-Mount
Sensor	1/2 inch
Focal Length	16 mm
Aperture	2
MOD	0.2 m
Back Focal	12.3 mm
Angle of View	D:27.8° H:22.1° V:16.8°
Megapixel	1-2 MP
IR Cut Filter	No
Weight	5 g
Iris	fixed
Focus	fixed
Typ	Standard

**SEDECO**  
IMAGING

Germany, Austria, Switzerland  
Sedeco Imaging GmbH  
Unterer Dammweg 12  
76149 Karlsruhe  
Germany  
T. +49 721 5604 7980  
info@sedeco-imaging.com

BeNeLux  
Sedeco Imaging B.V.  
Trasmolenlaan 12  
3447 CZ Woerden  
the Netherlands  
T. +31 348 749110  
info@sedeco-imaging.nl

[www.sedeco-imaging.com](http://www.sedeco-imaging.com)



Light Sensitive



Megapixel