

Dome Light

# NEO Dome Light

## IDDA-KH series

High-intensity dome light  
Extensive lineup available from  $\phi 60$  to  $\phi 350$



Power LEDs

DC 24V Models Available

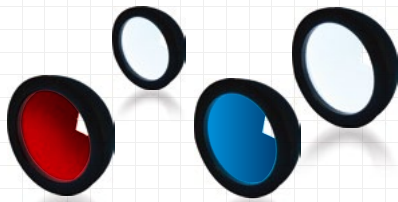

Model	Light Color	Power Consumption (W)	Input Voltage	SAG (*)	Power Supply	Drawing
IDDA-KH60□	R	6.5		FF		1
	AW					
	B					
IDDA-KH80□	R	9		FF		2
	AW					
	B					
IDDA-KH120□	R	13.5	DC12V	FF	ILP-30M2(P.69) IDGB series(P.67) other, overdrive power supply, etc.	3
	AW					
	B					
IDDA-KH150□	R	18		FF		4
	AW					
	B					
IDDA-KH220□	R	28.5		FF		5
	AW					
	B					
IDDA-KH270□HV	R	34	DC24V	—	ILP-60M2-24(P.69) IDGB-24 series (P.67)	6
	AW					
	B					
IDDA-KH350□HV	R	44	DC24V	—		7
	AW					
	B					

□ represents light color (R=Red, AW=White, B=Blue)

\* The SAG value indicates the maximum voltage setting for SAG power supplies.  
For details, see page 75.

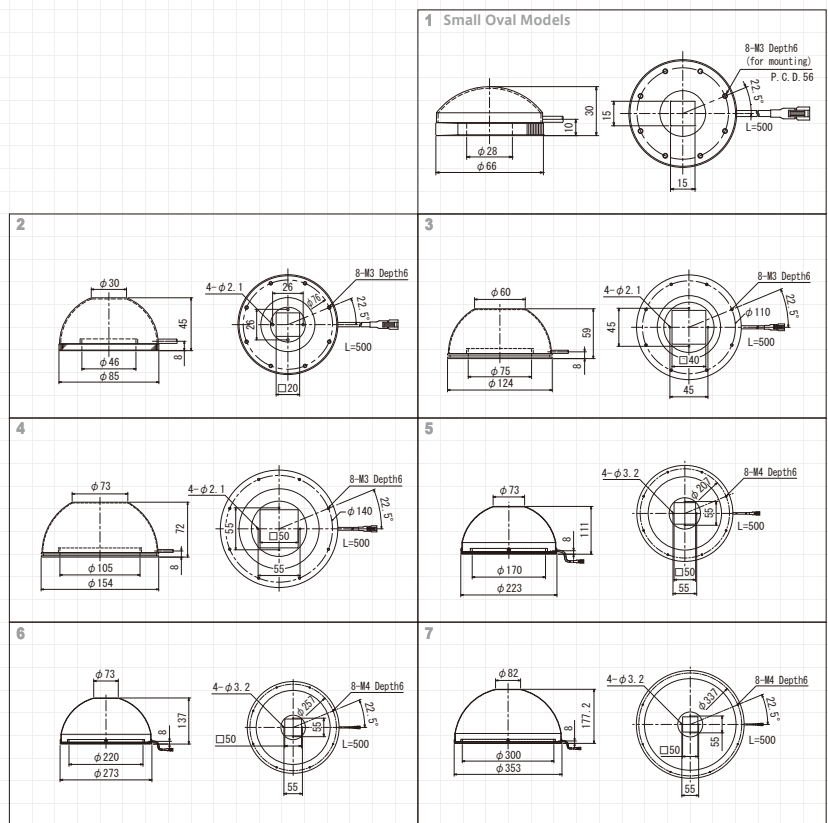

### Illuminance Comparison with Previous Models (eference Values) (WD=50mm)

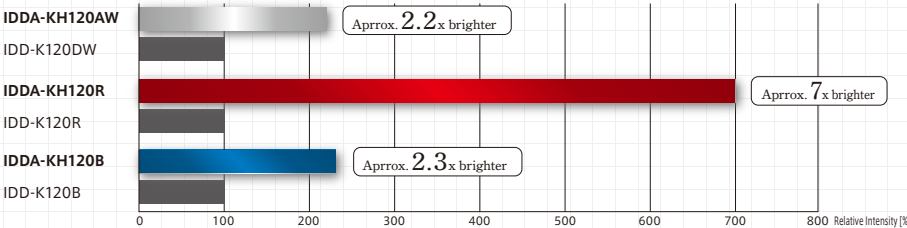

**Effect** Misalignment of an aluminum lid can be clearly recognized by changing the wavelength band. The bottom surface of a deep paper cup can be illuminated brightly and uniformly.

