

# Theia SL183M

## SL183M envelope Theia Technologies

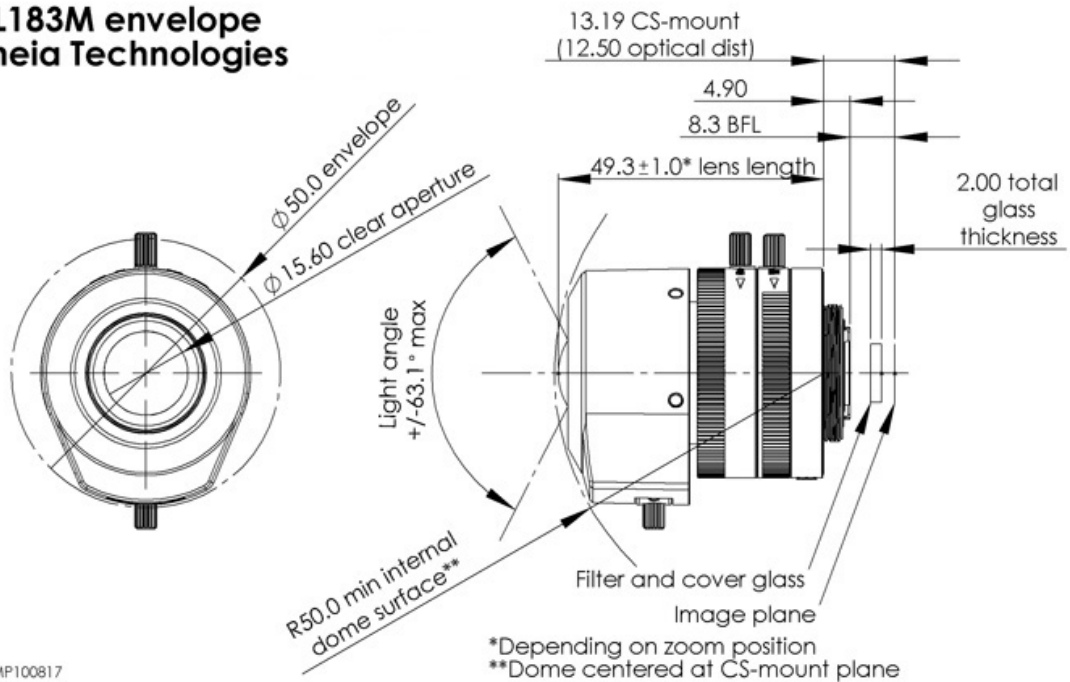

MP100817



The CS-Mount lens Theia SL183M is suitable for common sensors up to 5 megapixel with an image format of 1/2.5 inch. It is characterized by a particularly high light intensity.

### Technical Data

Mount	CS-Mount
Sensor	1/2.5 inch
Focal Length	1.8 mm
max. Focal Length	3 mm
Aperture	1.8
MOD	0.5 m
Back Focal	8.2 mm
Angle of View	D:126° H:115° V:99°
Megapixel	5 MP
IR Cut	No
Weight	59 g
Iris	manual-lock
Focus	manual-lock
Typ	Standard



Light Sensitive



5 Megapixel