

Lensagon CM1614MJ

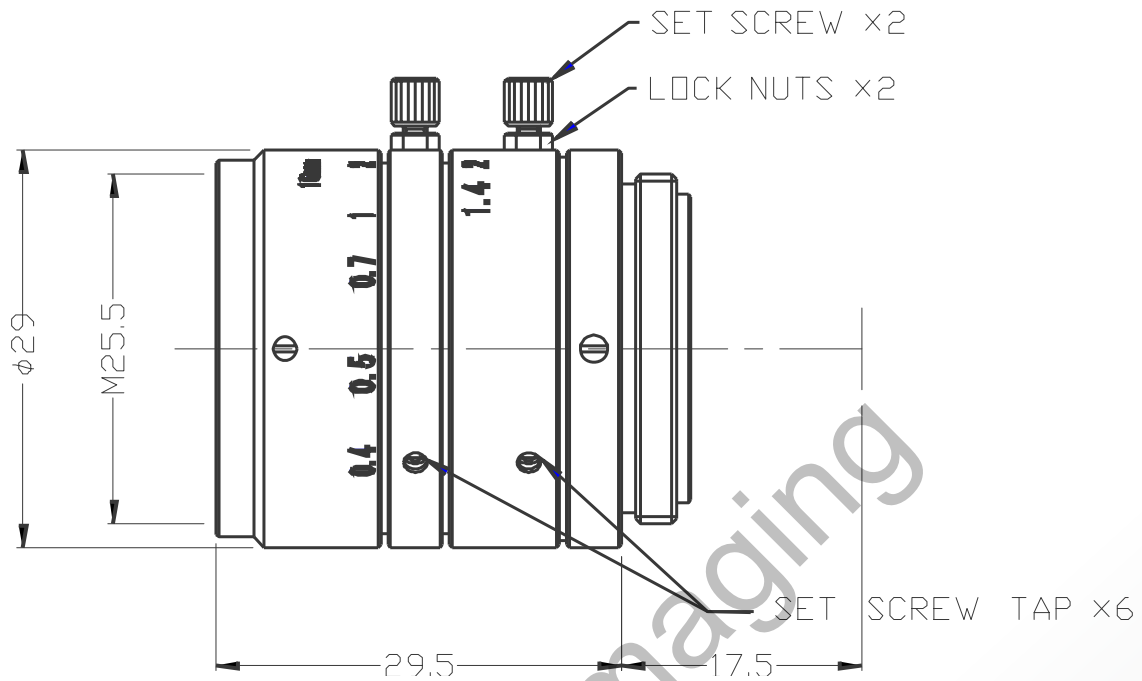

The C-Mount lens Lensagon CM1614MJ is suitable for common sensors up to 1 megapixel with an image format of 2/3 inch. It is characterized by a particularly high light intensity.

Technical Data

Mount	C-Mount
Sensor	2/3 inch
Focal Length	16 mm
Aperture	1.4
MOD	0.25 m
Back Focal	12.78 mm
Angle of View	D:37.9° H:30.7° V:23.3°
Megapixel	1-2 MP
IR Cut Filter	No
Distortion	-0.28 %
Weight	42 g
Iris	manual-lock
Focus	manual-lock
Filter	M25.5
Typ	Standard

SEDECO
IMAGING

Germany, Austria, Switzerland

Sedeco Imaging GmbH
Unterer Dammweg 12
76149 Karlsruhe
Germany
T. +49 721 5604 7980
info@sedeco-imaging.com

BeNeLux

Sedeco Imaging B.V.
Trasmolenlaan 12
3447 GZ Woerden
the Netherlands
T. +31 348 749110
info@sedeco-imaging.nl

www.sedeco-imaging.com



Light Sensitive

1

Megapixel