

# Low-Cost High-Performance Line Light

## IDBA-RK series

Highly cost-effective model  
Replaceable from fluorescent light



Low cost

Power LEDs

- Smartly-priced high-performance line light by inheriting developed lighting technologies
- Perfect for replacement of fluorescent light for inspection
- Lineup includes the emission light sizes from 200 to 2,400 mm in 200 mm increments

Model	Light Color	Power consumption (w)	Input Voltage	Power Supply	Drawing
IDBA-RK200W	W	19	DC48V	IWDV-300SL-48 (Analog) IWDV-300S-48 (Digital) (P.63·64)	n=2
IDBA-RK400W	W	38			n=4
IDBA-RK600W	W	57			n=6
IDBA-RK800W	W	76			n=8
IDBA-RK1000W	W	95			n=10
IDBA-RK1200W	W	114			n=12
IDBA-RK1400W	W	133			n=14
IDBA-RK1600W	W	152			n=16
IDBA-RK1800W	W	171			n=18
IDBA-RK2000W	W	190			n=20
IDBA-RK2200W	W	209			n=22
IDBA-RK2400W	W	228	n=24		

### Wide Selection of Sizes

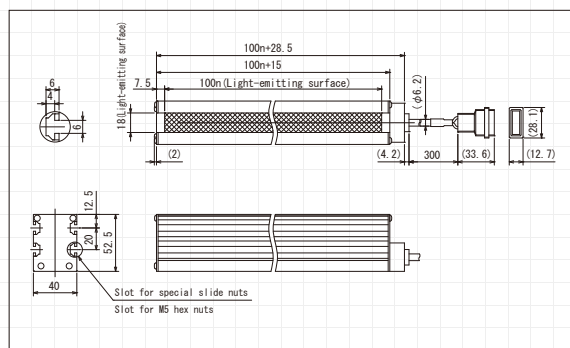
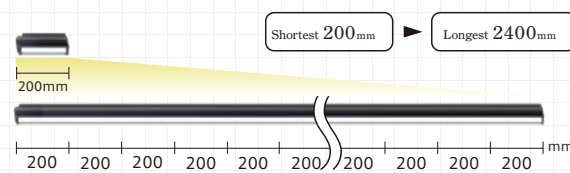

### Dedicated extension cable for IDBA-RK

Model	Length(m)
I-CB-S1-DN	1
I-CB-S2-DN	2
I-CB-S3-DN	3
I-CB-S5-DN	5
I-CB-S7-DN	7
I-CB-S10-DN	10

### Inspection for contaminants on film



### Luminance Distribution Chart (Reference Values)

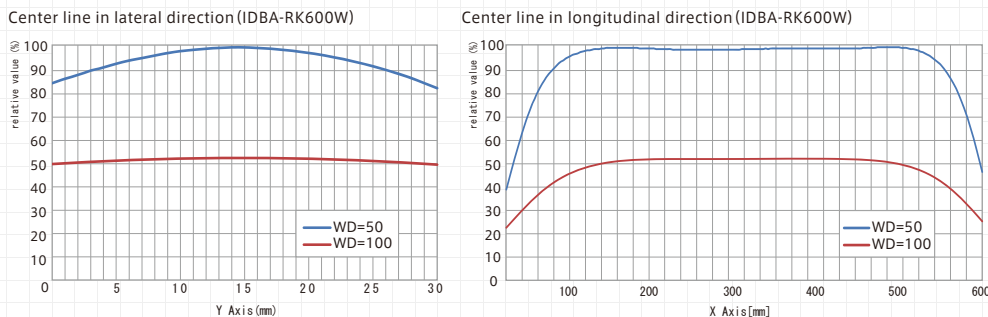

Power Supply (voltage light control)

IWDV-300S-48 (Digital)  
IWDV-300SL-48 (Analog)

Light control: 1000 levels  
External control: LAN control/10-bit parallel



details are described in P63·64

